

**DATA SHEET FOR  
LUNDS STANDARD FM52 ADJUSTABLE DROP BRACKET  
Part No. 070709-420 1000 DROP  
Part No. 070709-425 2000 DROP**



Our latest version of the Adjustable Drop VEID Bracket Assembly is designed to interface with the Infotec FM range of Video Displays (LED) FM42W and FM52W

This bracket has been the subject of an intensive analysis by our Structural Engineers regarding wind loadings especially in Tunnel Ring configurations where one drop arm is cut shorter than the other. This will introduce a natural tendency for the bracket to twist along its lateral axis. To minimise the effect of this our designers have added an additional pivot down the central axis of the drop arms. This will make the bracket cope more easily with these stresses.

The supplied drop length will be either 1000mm or 2000mm to the top of the VEID unit and may be cut down to suit on site to a minimum of 500mm. The Standard Top Fixing Plate with its unique pivoting head is ideal if direct fixing to steelwork with Lindapters.

The assembly has laser cut transitions and is allowed to pivot with air movement and will be stable enough not to require any further bracing.

The vertical arms can be moved along the bottom crossbar to allow convenient positioning on the roof substrate.

Cable runs are through the top and bottom conduit points on the uprights. All fixings used will be Grade 8 High Tensile BZP.

The finish is zinc & colour passivated plating with a DuPont ALESTA or equivalent Powder Paint to either RAL 9006 (White) or NCS 6502-R (Dark Grey) or nearest commercial equivalent. This complies with London Undergrounds No-Smoke, Zero Halogen fire test policy.

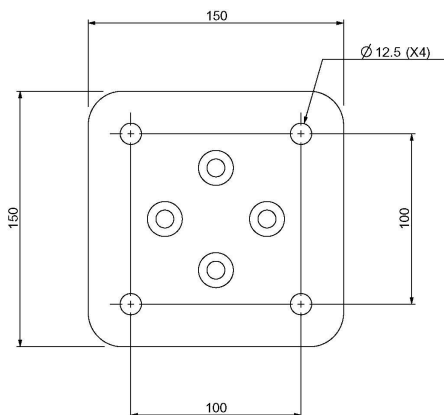

Drillings for Top Plate fixing.  
Nominal Hole size is  
12.5mm for 12mm fixings.



**LUND BROS. & Co. Ltd.**  
BROOKSIDE AVENUE • RUSTINGTON  
WEST SUSSEX • BN16 3LF  
TEL. 01903 784242 • FAX. 01903 787126  
EMAIL sales@lunds.co.uk  
WEB. www.lunds.co.uk

**DATA SHEET FOR  
LUNDS STANDARD FM52 ADJUSTABLE DROP BRACKET  
Part No. 070709-420 1000 DROP  
Part No. 070709-425 2000 DROP**

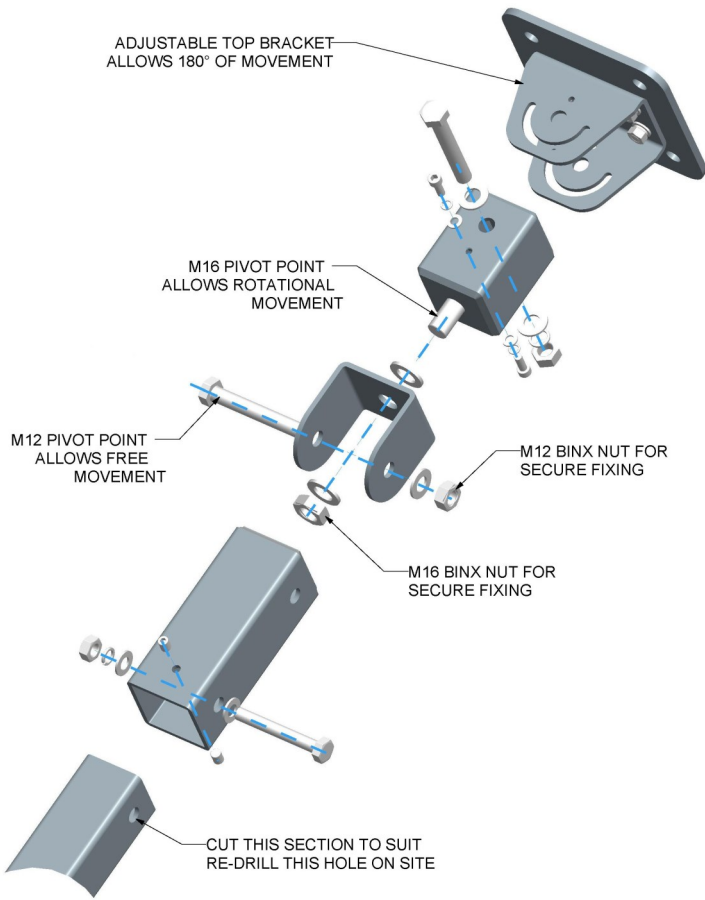

The top fixing plate is 6 mm thick mild steel plate, the pivot saddle bracket is 4 mm thick mild steel plate. The top joint section is 60 X 60 X 4 SHS and the free movement pivot is also 4mm thick mild steel plate. The drop section is 50 X 50 X 4 SHS and fits inside the 60 X 60 X 4 SHS top joint section. The bottom plate is 6 mm thick mild steel plate.

All fixings used are 8.8 grade high tensile steel and finished bright zinc plate. On the pivot points we use Binx Nuts (Lock nuts) to eliminate loosening due to movement.

All conduit tappings are M25 and capped with M25 nylon blanking plugs.

