

**DATA SHEET FOR
LUNDS STANDARD SPREADER PLATE
Part No. 151105-055**

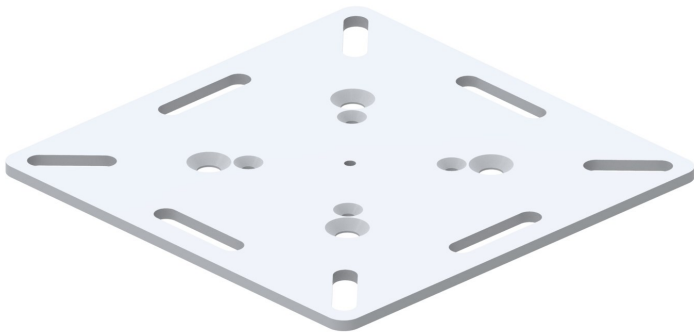
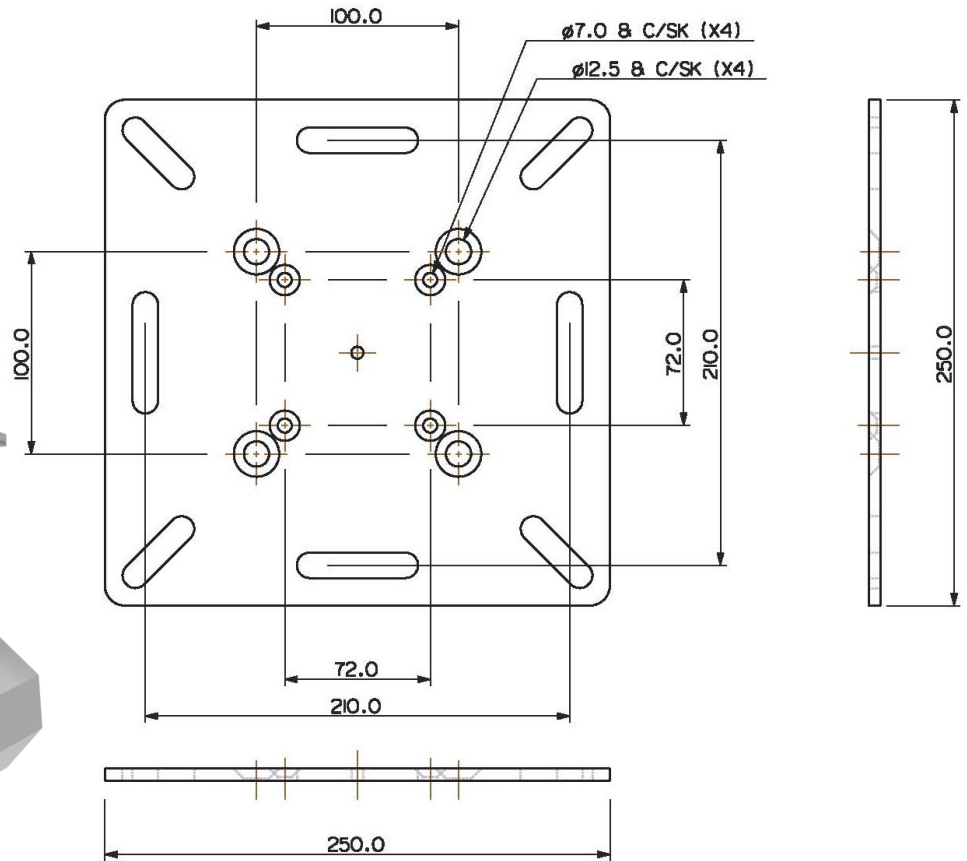
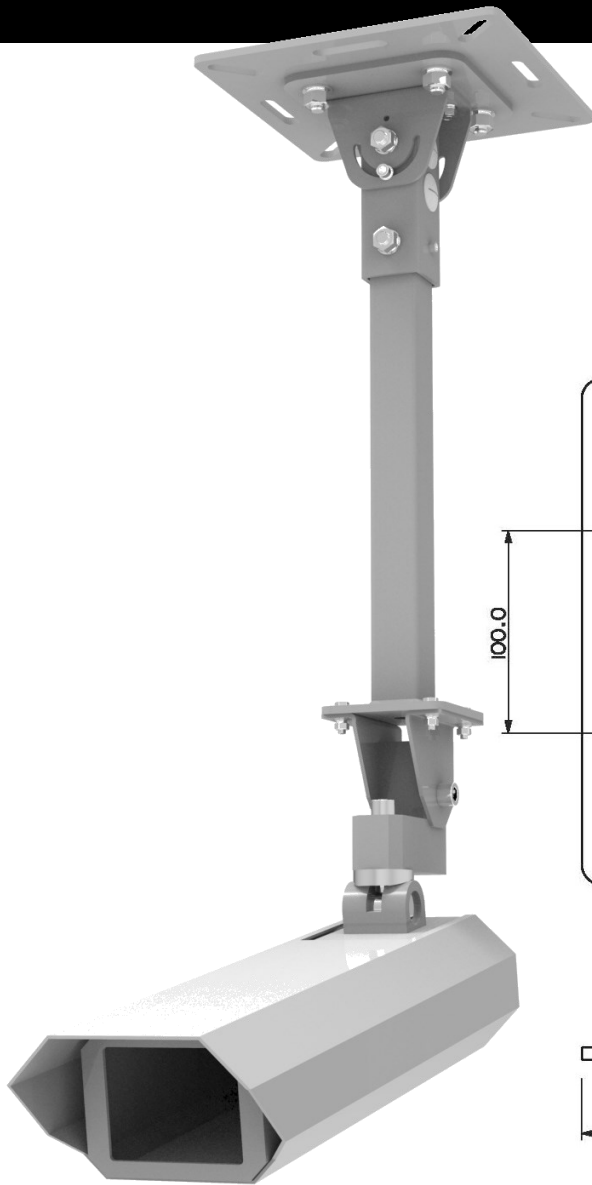

The Spreader Plate has drillings to interface with our Standard Drop Brackets either Part No.151105-501 for the 1 metre long bracket or Part No.151105-601 for the 2 metre long bracket.

A Dennard 504 Security Camera will mount directly to this plate if required.

Designed to spread the load over a greater surface area this plate has 12.5mm wide slots that will allow the plate to be fixed to steelwork with the use of lindapters.

The bracket assembly weighs approx. 3 Kilograms and is attached with suitable fixings. We would suggest bright zinc plated 8.8 grade fixings in all cases and suitable single coil or Shakeproof washers.

The base material is 6mm thick steel to BS EN 10029 : 1991/BS EN 10051 : 1992 and the welding is to BSEN287 & 288.

The finish is a zinc & colour plating operation and a DuPont ALESTA or equivalent Powder Paint to either RAL 9006 (White) or NCS 6502-R (Dark Grey) or nearest commercial equivalent. This complies with London Undergrounds No-Smoke, Zero Halogen fire test policy.



LUND BROS. & Co. Ltd.
BROOKSIDE AVENUE • RUSTINGTON
WEST SUSSEX • BN16 3LF
TEL. 01903 784242 • FAX. 01903 787126
EMAIL sales@lunds.co.uk
WEB. www.lunds.co.uk