

**DATA SHEET FOR
LUNDS DOUBLE BOSCH UHO CAMERA BRACKET
Part No. 151105-331**

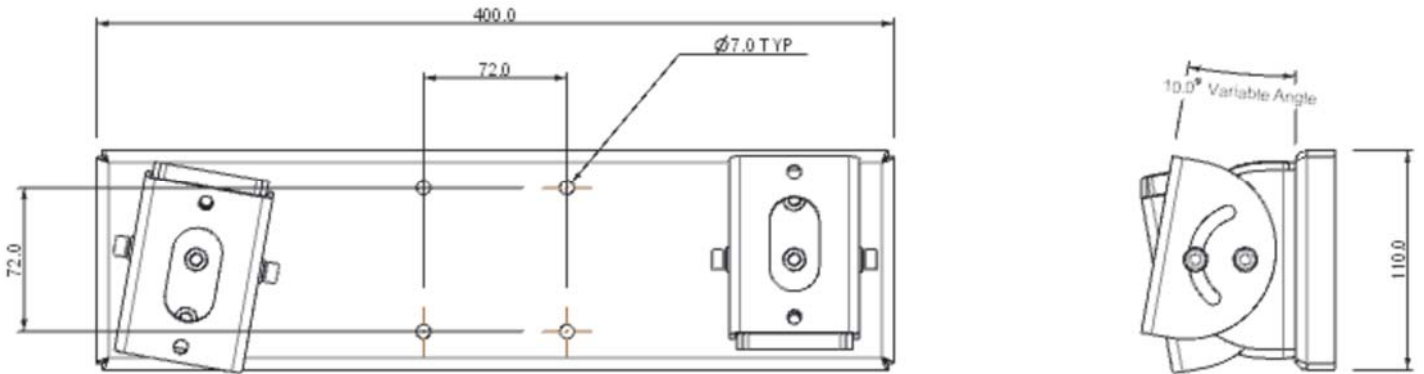

The Double Bosch UHO Camera Bracket has a gross weight of 2.7 Kilograms and is designed to mount 2 off the Bosch UHO Camera's to the base of our Standard Drop Brackets either Part No.151105-501 for the 1 metre long bracket or Part No.151105-601 for the 2 metre long bracket.

The camera's weigh approx. 3.1 Kilograms each and are attached with suitable M6 fixings. We would suggest bright zinc plated 8.8 grade fixings in all cases and suitable single coil or Shakeproof washers.

The calculated vertical load rating of the longest Drop bracket is in excess of 450 Kg without any allowance for wind loadings, so the combined weights fit comfortably within this range.

The base material is 3mm thick zinc coated steel to BS EN 10029 : 1991/BS EN 10051 : 1992 and the welding is to BSEN287 & 288.

The finish is a DuPont ALESTA or equivalent Powder Paint to either RAL 9006 (White) or NCS 6502-R (Dark Grey) or nearest commercial equivalent. This complies with London Undergrounds No-Smoke, Zero Halogen fire test policy.

View on Camera Fixing point

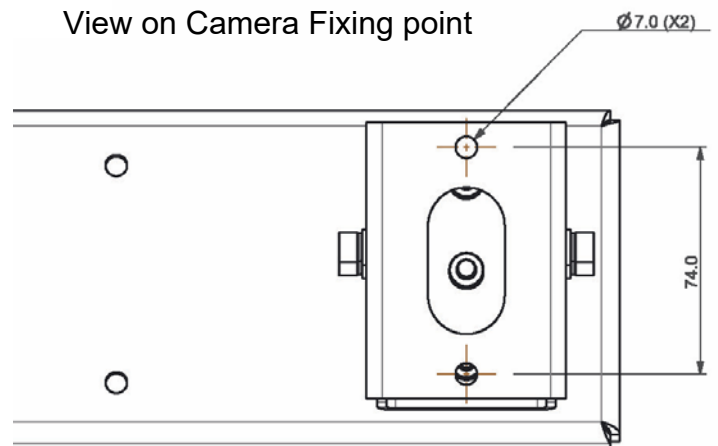

LUND BROS. & Co. Ltd.
BROOKSIDE AVENUE • RUSTINGTON
WEST SUSSEX • BN16 3LF
TEL. 01903 784242 • FAX. 01903 787126
EMAIL sales@lunds.co.uk
WEB. www.lunds.co.uk