

**DATA SHEET FOR  
LUNDS STANDARD VESA 200 ADAPTOR BRACKET  
Part No. 151105-302**

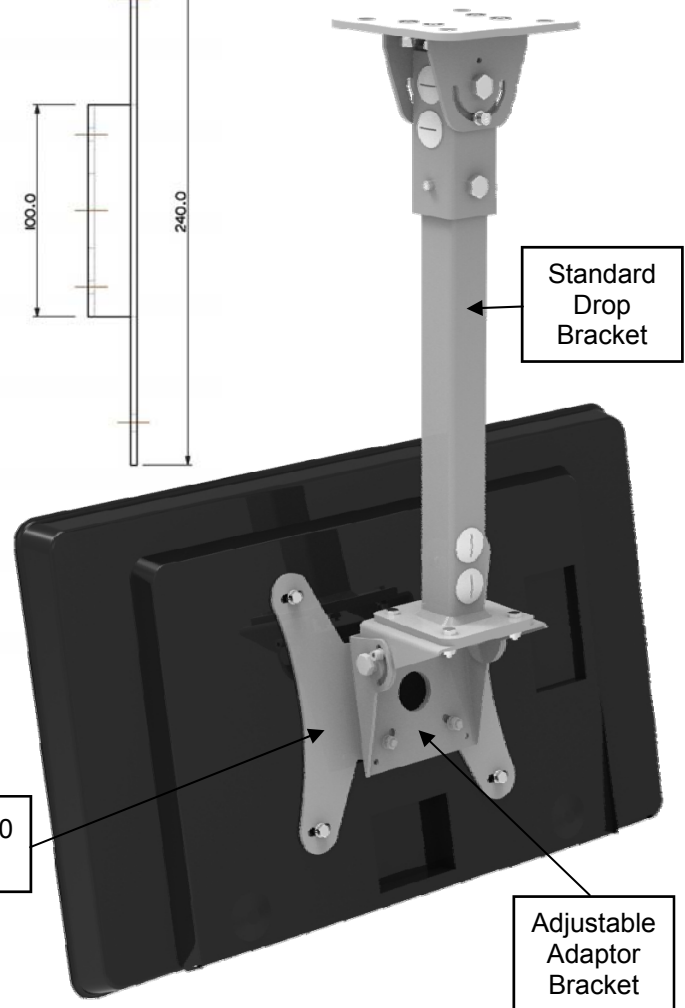
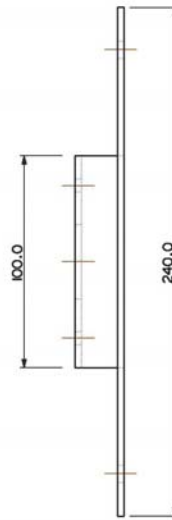
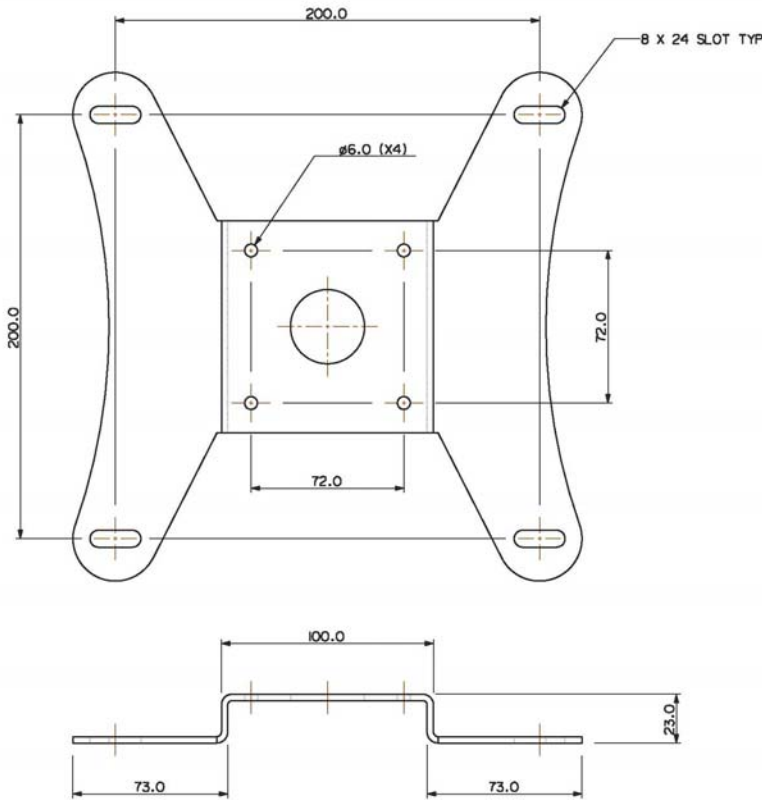

The VESA 200 Adaptor Bracket is designed to adapt the VESA 100 / PAM Adjustable Adaptor Bracket to a full VESA 200 compliant configuration. The bracket assembly fits to the base of our Standard Drop Brackets either Part No.151105-501 for the 1 metre long bracket or Part No.151105-601 for the 2 metre long bracket.

The bracket assembly weighs approx. 0.82 Kilograms and is attached with suitable M6 fixings. We would suggest bright zinc plated 8.8 grade fixings in all cases and suitable single coil or Shakeproof washers.

The calculated vertical load rating of the longest Drop bracket is in excess of 450 Kg without any allowance for wind loadings, so the combined weights fit comfortably within this range.

The base material is 3mm thick zinc coated steel to BS EN 10029 : 1991/BS EN 10051 : 1992 and the welding is to BSEN287 & 288.

The finish is a DuPont ALESTA or equivalent Powder Paint to either RAL 9006 (White) or NCS 6502-R (Dark Grey) or nearest commercial equivalent. This complies with London Undergrounds No-Smoke, Zero Halogen fire test policy.



**LUND BROS. & Co. Ltd.**  
**BROOKSIDE AVENUE • RUSTINGTON**  
**WEST SUSSEX • BN16 3LF**  
**TEL. 01903 784242 • FAX. 01903 787126**  
**EMAIL sales@lunds.co.uk**  
**WEB. www.lunds.co.uk**